

Provided for non-commercial research and education use.
Not for reproduction, distribution or commercial use.

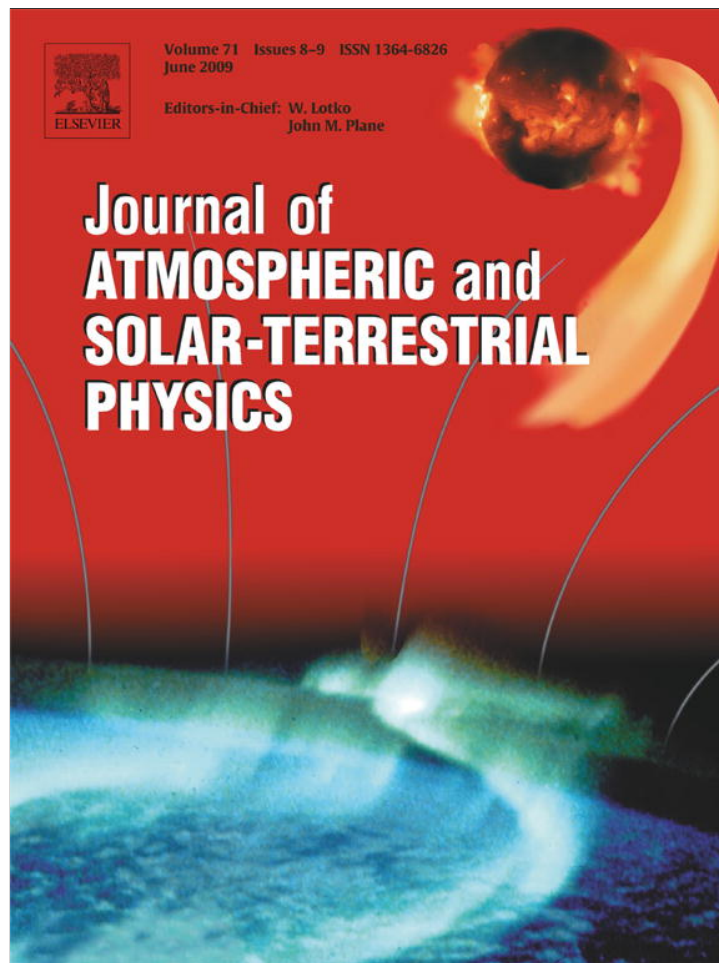

This article appeared in a journal published by Elsevier. The attached copy is furnished to the author for internal non-commercial research and education use, including for instruction at the authors institution and sharing with colleagues.

Other uses, including reproduction and distribution, or selling or licensing copies, or posting to personal, institutional or third party websites are prohibited.

In most cases authors are permitted to post their version of the article (e.g. in Word or Tex form) to their personal website or institutional repository. Authors requiring further information regarding Elsevier's archiving and manuscript policies are encouraged to visit:

<http://www.elsevier.com/copyright>



Contents lists available at ScienceDirect

Journal of Atmospheric and Solar-Terrestrial Physics

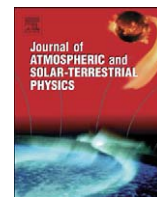
journal homepage: www.elsevier.com/locate/jastp

Impairment of radio wave signal by rainfall on fixed satellite service on earth–space path at 37 stations in Nigeria

T.V. Omosho*, C.O. Oluwafemi

Department of Physics, Covenant University, Ota, Ogun State, Nigeria

ARTICLE INFO

Article history:

Received 7 August 2008

Received in revised form

18 February 2009

Accepted 8 March 2009

Available online 1 April 2009

Keywords:

TRMM and AIRS satellite data

Ku, Ka and V bands

Slant-path rain attenuation

Fixed satellite services

ABSTRACT

This study investigates the effect of rainfall on horizontally polarized radio waves for fixed satellite service at Ku, Ka and V bands for links to the recently launched Nigeria Communication Satellite one (NigComSat-1), for annual time availabilities of 99–99.99% in an average year for 37 stations in Nigeria. The results obtained at Ku-band downlink shows that 99.99% availability is possible in all the 37-stations in Nigeria. At Ka-band downlink the results also show that only 99.9% availability is practicable in all the 37 stations in Nigeria. At V-band downlink, 99.99% availability is also not possible in all the 37 stations in Nigeria. An availability level of 99.9% is only practicable in the North–West (NW) and North–East (NE) regions, where the attenuation is between 14 and 17.9 dB. Total fade out of signals during rainfall are probable in the South–South (SS), South–East (SE), South–West (SW) and Middle–Belt (MB) regions at 99.9% availability.

© 2009 Elsevier Ltd. All rights reserved.

1. Introduction

The performance of radio (wireless) communication systems depends on the propagating medium between the transmitter and the receiver, the atmosphere. Unlike wired channels that are stationary and predictable, the radio channels are extremely random, because they depend on the physical characteristics of the atmosphere such as temperature, pressure, humidity, hydrometeors-suspended particles and atmospheric constituents and also the propagating wave itself depend on the wavelength and its polarization as it travels through the atmosphere (Margarita, 2005). The effect of the propagating medium (atmosphere) increases as the frequency of the signal increases (Gibson, 2002). Electromagnetic wave propagating characteristics vary significantly over different frequency bands; therefore, it is vital to thoroughly understand the propagating characteristics and develop (use or modify an existing) a channel model for the proposed wireless communication system before site-specific planning and deployment can be initiated. Absorption and scattering by rain (and to a lesser extent hail, ice crystals or wet snow) at frequencies above 10 GHz can cause a reduction in transmitted signal amplitude (attenuation), which in turn reduce the reliability,

availability and performance of the communications link (Sarkar, 1998).

Other degradation caused by these hydrometeors along the earth–space paths to microwave signals includes depolarization, rapid amplitude and phase fluctuation (scintillation), antenna gain degradation and bandwidth coherence reduction. The NASA Advanced Communication Satellite (ACTS) had completed a very successful five-year campaign of measurements in the 20 and 30 GHz bands (Ka and V bands) at seven North America locations (Ippolito, 1986) also similar propagation campaigns in Europe (at Ka and V bands) had been completed successfully (Olympus and Italsat). Concise modeling and prediction procedures for propagation factors based on data from satellite beacons have been successfully applied in the design and performance of satellite telecommunication systems for several years (Ippolito, and Bauer 2000). The main objective of this study is to estimate impairments by rainfall on earth–space path for 0.01–1% unavailability of an average year in Nigeria for links to recently launched Nigeria Communication Satellite One (NigComSat-1) by using recent meteorological data from satellites such as the TRMM satellite, the AIRS satellite (from NASA, USA) and GTOPO30 (USA) covering 1998–2006, 2002–2006 and 2004, respectively. For ease of data analyses in this work, the 37 stations (Fig. 1) in Nigeria have been divided into six distinct regions namely: South–West (SW), South–East (SE), South–South (SS), Middle–Belt (MB), North–West (NW) and North–East (NE). Table 1 gives a brief description of the topographic features along with the climate summary of each region.

* Corresponding author. +23408050401655 (Mobile).
E-mail address: dayovic@yahoo.com (T.V. Omosho).

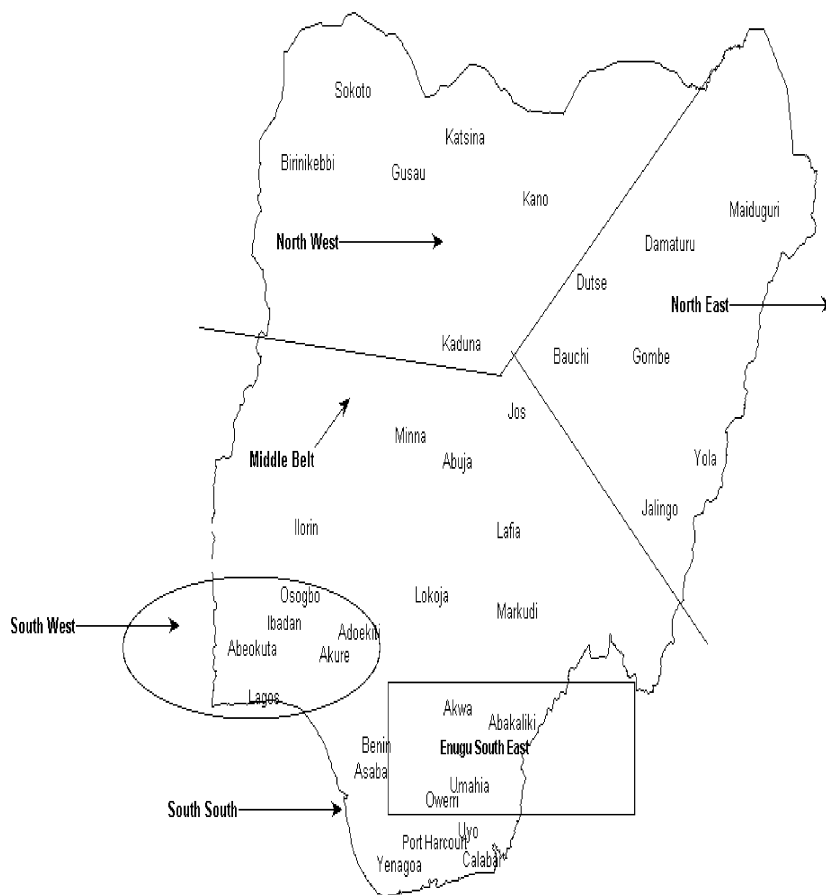

Fig. 1. Map of Nigeria showing the 37 stations used in the study.

2. Computational methods

2.1. Data source (rainfall archives)

TRMM Data from EOS DAAC NASA Goddard space flight centre Maryland US were used. They included:

- (a) Monthly TMI rain product (3A12 V6) containing surface, convective and stratiform rain rates in mm/h. As it applies to TRMM satellite, stratiform rain is a widespread continuous precipitation produced by large-scale ascent due to frontal or topographic lifting or large-scale horizontal air convergence caused by other means, while convective rain is a localized, rapidly changing, showery precipitation produced by cumulus-scale convection in an unstable air. The third type comprises all rain that is not included in these two categories. When the bright band does exist, rain is classified as stratiform. When the bright band does not exist, but any value of Z along the range exceeds a predetermined value, rain is classified as convective. When the bright band does not exist and all values of Z along the range are less than the predetermined value, rain is classified as others (Nirala and Cracknell, 2002). The 3A12 V6 data set was based on 1° latitude by 1° longitude spacing.
- (b) Monthly TRMM and other satellite data sources. Rainfall estimate (3B43 V6) is one of the operational products of TRMM based on rain gauge measurements and satellite estimates of rainfall. The algorithm was developed by the TRMM science team and the data were processed by the

TRMM science data and information system. The gridded estimates are on a temporal resolution of 0.25° latitude by 0.25° longitude spacing. The combined data set is based on the concepts of Huffman et al., (1995) combining precipitation data sets. The TRMM best estimates method is a combination of data from the TMI, PR and VIRS, with SSM/I, IR and rain gauge data.

2.2. Data processing

For each of the 37 stations, the thunderstorm ratio β was calculated using the method of Rice and Holmberg (1973). The model divided the rainfall into two types to permit the prediction of rainfall rate statistic from the total rainfall accumulation measured in an average year. The two types are termed mode 1 rain (M1) and mode 2 rain (M2). Mode 1 contained the high rainfall rates associated with strong convective activity and thunderstorms. Mode 2 was simply everything else. Therefore, the total average rainfall accumulation M is

$$M = M1 + M2 \text{ mm.} \quad (1a)$$

Since TRMM, PR and TMI are able to detect and log stratiform rain and convective rain mode associated with thunderstorm separately. Therefore, the ratio of thunderstorm rain accumulation to the total rainfall accumulation, namely

$$\beta = M1/M. \quad (1b)$$

The one-minute rainfall rate was computed using the method developed by Chieko and Yoshio (2002) in which regional climatic

Table 1
Topographic and climate data: heights above mean sea level (m), zero degree isotherm height (m), rain height (km), annual rainfall and surface temperature, derived from GTOPO30, TRMM and AIRS satellite for the 37 stations.

Regions	State capitals	Climate	Latitude	Longitude	Station height above sea level (m)	OC isotherm height(m)	Rain heightt (Km)	Annual rainfall (mm)	Surface temperature
South West	Abeokuta	Tropical wet	7.07	3.21	74.0	4411.0	4.77	1100.0	28.6
	Adoekiti	Tropical wet	7.42	5.13	363.0	4392.0	4.75	1242.0	27.6
	Akure	Tropical wet	7.18	5.12	303.0	4392.0	4.75	1314.0	27.6
	Ibadan	Tropical wet	7.21	4.01	134.0	4402.0	4.76	1245.0	27.7
	Ikeja	Tropical wet	6.35	3.20	38.0	4398.0	4.76	1217.0	27.2
	Osogbo	Tropical wet	7.42	4.31	229.0	4402.0	4.76	1245.0	27.7
South East	Abakaliki	Tropical wet	6.18	8.70	149.0	4408.0	4.77	2394.0	28.7
	Akwa	Tropical wet	6.12	7.04	159.0	4395.0	4.75	1899.0	28.4
	Enugu	Tropical wet	6.24	7.24	139.0	4395.0	4.75	1899.0	25.1
	Owerri	Tropical wet	5.19	7.07	158.0	4387.0	4.75	2397.0	27.4
	Umuahai	Tropical wet	5.30	7.33	165.0	4387.0	4.75	2397.0	27.4
	South South	Asaba	Tropical wet	6.10	6.44	152.0	4377.0	4.74	1900.0
Benin		Tropical wet	6.22	5.39	42.0	4379.0	4.74	1948.0	27.2
Calabar		Tropical wet	4.55	8.25	370.0	4404.0	4.76	3748.0	26.6
Port harcourt		Tropical wet	4.43	7.02	18.0	4381.0	4.74	2817.0	26.7
Uyo		Tropical wet	5.00	7.57	163.0	4387.0	4.75	2429.0	27.4
Yenagao		Tropical wet	4.55	6.16	93.0	4379.0	4.74	2766.0	26.4
Middle Belt		Abuja	Savanna North	9.04	7.28	334.0	4402.0	4.76	1258.0
	Ilorin	Savanna North	8.32	4.34	304.0	4415.0	4.78	1132.0	29.7
	Lafia	Savanna North	8.29	8.34	403.0	4405.0	4.77	1146.0	30.6
	Lokoja	Savanna North	7.47	6.44	204.0	4389.0	4.75	1334.0	28.8
	Markurdi	Savanna North	7.41	8.35	142.0	4405.0	4.76	1398.0	29.7
	Minna	Savanna North	9.33	6.33	152.0	4426.0	4.79	1049.0	30.9
	Jos	Savanna North	9.58	8.57	1110.0	4397.0	4.76	1184.0	30.1
	North West	Birini kebbi	Semi-arid	12.28	4.08	244.0	4421.0	4.78	764.0
Gusau		Semi-arid	12.18	6.27	440.0	4420.0	4.78	721.0	33.3
Kaduna		Savanna North	10.32	7.25	605.0	4410.0	4.77	1112.0	30.7
Kano		Semi-arid	11.56	8.26	566.0	4411.0	4.77	754.0	31.6
Kastina		Semi-arid	12.56	7.33	590.0	4415.0	4.77	600.0	32.7
Sokoto		Semi-arid	13.05	5.15	247.0	4430.0	4.79	564.0	33.9
North East	Bauchi	Savanna North	10.18	9.46	665.0	4416.0	4.78	863.0	31.2
	Damaturu	Semi-arid	11.44	11.58	451.0	4412.0	4.77	598.0	33.2
	Dutse	Semi-arid	11.43	9.25	452.0	4422.0	4.78	649.0	32.8
	Gombe	Savanna North	10.19	11.02	422.0	4428.0	4.79	759.0	32.6
	Jalingo	Savanna North	8.54	11.22	304.0	4389.0	4.75	1417.0	30.1
	Maiduguri	Semi-arid	11.51	13.09	343.0	4416.0	4.78	650.0	33.8
	Yola	Semi-arid	9.07	12.24	207.0	4414.0	4.77	1027.0	33.1

parameters such as the thunderstorm ratio β was taken into account in the estimation of the one-minute rainfall rate. This model was found to give the best prediction accuracy among existing models, especially for small percentage of time (0.001–1%) which is important for radio system design. From their result, it was found that the thunderstorm ratio was an important parameter. As the results of their analysis, one-minute rain rates for arbitrary percentage of time P (%), R_p (mm/h), can be estimated by using only the average annual total rainfall and the thunderstorm ratio. The model is given by Eqs. (2)–(5) using coefficients a_p , b_p , c_p , with $x = \log(P)$. The equations were determined by multiple regression analyses of databank of rain attenuation on satellite links of 290 data sets from 84 locations in

30 countries and the databank of different integration time rain rates which contains data sets from 54 locations in 23 countries.

$$R_p = a_p M^{b_p} \beta^{c_p} \tag{2}$$

$$\log(a_p) = 0.1574155x^4 + 1.348171x^3 + 3.528175x^2 + 1.479566x - 2.302276 \tag{3}$$

$$b_p = -4.583266 \times 10^{-2}x^4 - 0.4098161x^3 - 1.162387x^2 - 0.8261178x + 0.911857 \tag{4}$$

$$c_p = 2.574688 \times 10^{-2}x^4 + 0.1549031x^3 + 0.1747827x^2 - 0.2846313x + 1.255081 \times 10^{-2} \quad (5)$$

For the computation of the derived one-minute rainfall rates, a program named *Rain rate* was written in Matlab 7.0, which can be called in Microsoft excel as a function, taking input parameters like annual rainfall accumulation *M* in mm, thunderstorm ratio β and percentage of time unavailability *P* in %, respectively.

2.3. Validation of TRMM data with measured rainguage data in Nigeria

Rainguage data from January 1991 to December 2000 were collected for 14-locations for the validation of TRMM data. The TRMM satellite started its mission in November 27, 1997; ground data from January 1998 to December 2000 were used to validate the closeness of the TRMM satellite data with the rainguage data in the selected locations, which cover the entire six regions in Nigeria. Table 1 shows the seasonal variation of mean precipitation, mean bias error and correlation coefficients of TRMM 3B43V6 Data with the ground data collected at the National Meteorological Centre Oshodi Lagos. The results show that TRMM data were positively correlated with the rainguage data in all the 14-locations. In the SW region, the seasonal correlation coefficients from December to November varies from 0.58 to 0.99, 0.75 to 0.99 in the SE, 0.83 to 0.99 in the SS, 0.56 to 0.96 in the MB, 0.76 to 0.99 in the NW and 0.76 to 0.96 in the NE regions. Table 2 also shows the seasonal mean bias error of TRMM 3B43V6 data with ground data. Mean bias errors greater than –25 mm occurred in March, April, May (MAM) in two locations, Adoekiti and Kano (the end of dry months). During June, July, August (JJA, the wettest months), the mean bias errors less than –50 mm occurred in one location Kano. The mean bias errors were smallest in the peak of raining season (JJA) for 13-locations. In September, October, November (SON), the seasonal mean bias errors greater than +25 mm occurred in five locations: Adoekiti, Port hacourt, Yenagoa, Kaduna and Jalingo. Adeyewa and Nakamura (2003) had observed similar seasonal mean bias error (for latitudes 4° to 14°N in Africa) of 25–40, 28–53, 38–54 and 35–45 mm of TRMM

3B43V6 data with rainguage data for MAM, JJA and SON, respectively.

The worst bias errors (greater than +100 mm) occur in (the driest months) December, January, February (DJF), at ten stations.

2.4. Cumulative distribution of rainfall rates in the six regions

The average cumulative distributions of rain rate observations for the 9-year period for the six regions are shown in Fig. 2. The rain rates were plotted against percentage of time unavailability, from 0.001% to 1% which corresponds to 5.26 min–8.76 h of exceedance of the indicated one-minute rainfall rates in an average year. The cumulative graphs show that the SE (Abakaliki and Umahia) and SS (Uyo) regions have the highest cumulative (of 4–192 mm/h), followed in descending order by the MB (Markudi, 2–164 mm/h) SW (Akure and Osogbo, 2–162 mm/h). The cumulative distribution was the lowest in the NW and NE with values of 1–153 and 1–162 mm/h, respectively.

2.5. Validation of the derived rainfall rate from TRMM with other works

Table 3 shows the correlation coefficient of the derived rainfall rates with International Telecommunication Union Radio waves Propagation Study Group 3 digital maps (ITU_RP SG3) and with the work of Ajayi and Ezekpo (1988) which relied on the Rice Holmberg (1973) method to predict 1 min rainfall rate from 30-year rainguage data for 37 stations in Nigeria. Ajayi and Ezekpo derived a contour map of rainfall rate for Nigeria. The correlation coefficients between this present work and ITU-RP is positive in all regions except in the Middle-Belt, where there is negative correlation (of 0.20). In Table 3, two outliers in the ITU-RP rain rate data for Lokoja and Minna seem to be the cause of the negative correlation. There is also a weak correlation (0.09) between this work and ITU-RP only at the South–South region, due to low values of ITU-RP rain rate data for Uyo and Yenagoa. This suggests that where local measured data is not available, ITU-RP digital map is applicable only in the SW, SE, NW and NE. The correlation coefficient of this work with Ajayi-Ezekpo (1988) is positive in all regions, but there are also two weak correlations (of 0.17) at the

Table 2

The seasonal variation of mean precipitation, percentage mean bias error and overall correlation coefficients of TRMM 3B43V6 data with ground data at 14 locations in Nigeria for the period January 1998–December 2000.

Regions/climate	Locations	(A) Ground data mean precipitation (mm)				(B) TRMM 3B43V6 data mean precipitation (mm)				(B–A)/A × 100 percentage mean bias error				Overall correlation coefficients of (A) with (B)			
		DJF	MAM	JJA	SON	DJF	MAM	JJA	SON	DJF	MAM	JJA	SON	DJF	MAM	JJA	SON
South West Tropical wet	Adoekiti	16.6	187.3	200.7	83.4	12.1	130.6	179.2	146.1	–27.1	–30.3	–10.7	75.2	0.58	0.93	0.97	0.81
	Ibadan	14.9	90.2	187.7	145.0	14.3	130.9	166.7	152.0	–4.0	45.1	–11.2	4.8	0.57	0.93	0.94	0.99
	Ikeja	14.2	85.0	160.1	167.4	11.5	126.4	178.3	108.4	–19.0	48.7	11.4	–35.2	0.90	0.95	0.99	0.97
South East Tropical wet	Enugu	8.1	147.2	244.5	174.8	23.4	137.2	310.6	152.0	188.9	–6.8	27.0	–13.0	0.75	0.91	0.95	0.99
South South Tropical wet	Calabar	85.9	190.5	387.6	336.2	61.4	217.3	555.3	411.7	–28.5	14.1	43.3	22.5	0.91	0.89	0.95	0.99
	Port Harcourt	24.5	176.8	305.7	287.6	70.9	153.8	426.2	374.3	189.4	–13.0	39.4	30.1	0.85	0.94	0.98	0.96
	Yenagoa	28.8	131.6	193.1	211.0	76.5	190.3	264.3	333.1	165.6	44.6	36.9	57.9	0.71	0.92	0.83	0.94
Middle Belt Savanna North	Ilorin	5.6	91.6	206.5	154.6	26.2	104.4	163.2	108.6	367.9	14.0	–21.0	–29.8	0.83	0.90	0.93	0.94
	Minna	0.0	45.3	247.1	88.7	6.2	92.1	184.6	98.5	**	103.3	–25.3	11.0	0.56	0.77	0.96	0.87
	Jos	0.0	91.7	211.6	93.3	7.2	82.4	212.2	96.7	**	–10.1	0.3	3.6	0.79	0.90	0.96	0.96
North West Savanna North	Kaduna	0.0	46.9	217.1	67.7	6.7	41.7	204.6	120.4	**	–11.1	–5.8	77.8	0.76	0.86	0.97	0.73
	Kano	0.0	25.2	363.2	104.1	3.5	5.8	174.2	55.5	**	–77.0	–52.0	–46.7	0.75	0.99	0.98	0.99
North East Savanna North Semi-Arid	Jalingo	0.0	56.2	204.8	65.7	5.3	87.3	240.6	125.4	**	55.3	17.5	90.9	0.76	0.90	0.97	0.96
	Maiduguri	0.0	7.1	181.3	57.4	0.4	11.9	163.1	69.1	**	67.6	–10.0	20.4	1.00	1.00	0.94	0.96

Note: DJF = December, January, February; MAM = March, April, May; JJA = June, July, August; and SON = September, October, November.

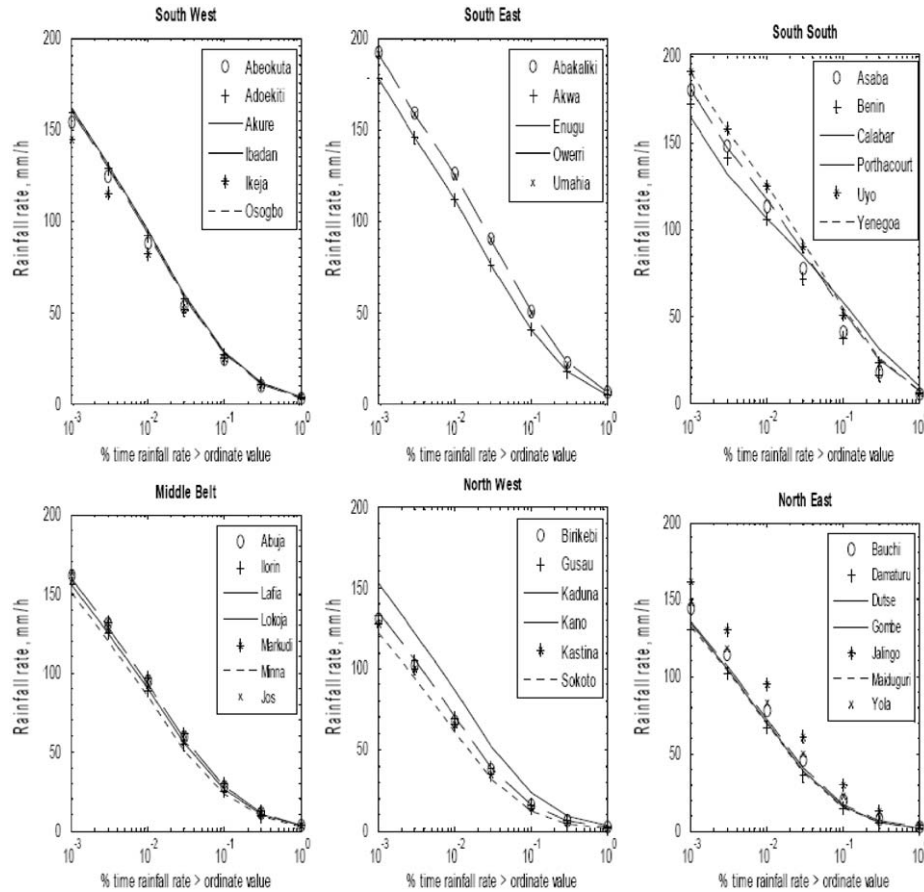

Fig. 2. Cumulative distribution of rainfall rates derived from TRMM Satellite for the 37 stations in Nigeria.

Table 3
Correlation of the derived one-minute rainfall rates with other works.

Regions	State capitals	ITU-RP SG3 digital map based data (A) mm/h	Present work based on TRMM 3B43V6, data (B) mm/h	Ajayi-Ezekpo contour map data (C) mm/h	Mean differences in region basis (A) and (B) mm/h	Mean differences in region basis (C) and (B) mm/h	Regional correlation coefficient of (A) with (B)	Regional correlation coefficient of (B) with (C)
South West	Abeokuta	90.0	87.0	118.0	3.5	27.0	0.91	0.17
	Adoekiti	93.0	92.0	117.0				
	Akure	95.0	94.0	116.0				
	Ibadan	96.0	93.0	117.0				
	Ikeja	88.0	79.0	116.0				
	Osogbo	98.0	94.0	117.0				
South East	Abakaliki	106.0	125.0	123.0	-18.6	3.8	0.98	0.87
	Akwa	96.0	11.0	122.0				
	Enugu	93.0	11.0	121.0				
	Owerri	105.0	125.0	125.0				
	Umuahia	104.0	125.0	125.0				
South South	Asaba	99.0	112.0	124.0	-8.2	10.2	0.09	0.58
	Benin	100.0	105.0	123.0				
	Calabar	114.0	105.0	125.0				
	Port Harcourt	110.0	116.0	125.0				
	Uyo	108.0	124.0	125.0				
	Yenagoa	106.0	124.0	125.0				
Middle Belt	Abuja	95.0	94.0	112.0	-2.4	23.6	-0.2	0.41
	Ilorin	91.0	89.0	114.0				
	Lafia	87.0	89.0	115.0				
	Lokoja	79.0	93.0	118.0				
	Markurdi	88.0	94.0	117.0				
	Minna	91.0	84.0	112.0				
	Jos	86.0	91.0	111.0				
North West	Birini kebbi	84.0	67.0	92.0				

Table 3 (continued)

Regions	State capitals	ITU-RP SG3 digital map based data (A) mm/h	Present work based on TRMM 3B43V6, data (B) mm/h	Ajayi-Ezekpo contour map data (C) mm/h	Mean differences in region basis (A) and (B) mm/h	Mean differences in region basis (C) and (B) mm/h	Regional correlation coefficient of (A) with (B)	Regional correlation coefficient of (B) with (C)
	Gusau	88.0	69.0	91.0	16.0	22.0	0.94	0.97
	Kaduna	102.0	86.0	108.0				
	Kano	83.0	70.0	95.0				
	Kastina	77.0	65.0	85.0				
	Sokoto	79.0	60.0	78.0				
North East	Bauchi	76.0	78.0	105.0	3.0	22.9	0.84	0.63
	Damaturu	75.0	66.0	93.0				
	Dutse	75.0	70.0	94.0				
	Gombe	76.0	71.0	103.0				
	Jalingo	88.0	95.0	102.0				
	Maiduguri	71.0	68.0	90.0				
	Yola	90.0	82.0	103.0				

Overall correlation coefficients for all sites (A) with (B) = 0.84
 Overall correlation coefficients for all sites (B) with (C) = 0.89

SW and (0.41) at the MB regions, due to high deminly contour lines of rainfall rates across the two regions. The overall correlation coefficients of the derived rainfall rates from all sites between this present work and the ITU_RP SG3 digital maps is 0.84, while with that of Ajayi-Ezekpo (1988) is 0.89. The work of Ajayi and Ezekpo was based on a 30-year data set, while this present work is based on a 9-year satellite data set. Long-term data is expected to smoothen out large variations, and these will improve agreement. The overall correlation coefficients of the derived rainfall rates from all sites between this present work and the ITU_RP SG3 digital maps is 0.84, while with that of Ajayi-Ezekpo (1988) is 0.89.

Measured one-minute rainfall rates for other tropical and subtropical locations around the world such as Brazil (Migliora et al., 1990), Cameroon (Moupfouma, 1987 and Moupfouma et al., 1990), Congo-Brazzaville (Ajayi et al., 1996), Kenya (McCarthy et al., 1994b), Malaysia and Hong-Kong (Yusof et al., 1990), India (Sarkar et al., 1992 and Sarkar, 1995), USA Miami-Florida (Sims and Jones, 1973) and Indonesia (Brussaard et al., 1993) were also compared with the results obtained for the 37-locatios in Nigeria, and the results are presented in Table 4. It is seen from the table that the measured rainfall rates obtained in tropical stations such as India (Shillong, Calcutta, and Bombay), Indonesia (Surabaya), Cameroon (Douala), Congo-Brazzaville and Vietnam (Ho-Chim), Australia (Darwin) are comparable with the values derived for tropical wet in the South–West, South–East and South–South part of Nigeria, while the results obtained for sub-tropical stations in Brazil (Alegre, Fortaleza, Rio de Janerio, Sao Paulo and Brasilia) are comparable with those of the Middle–Belt region in Nigeria.

2.6. Rain attenuation computation

There are about 16 rain attenuation models till date (Harris, 2002), the radio communication sectors of the International Telecommunication union (ITU-R) provides the prediction methods and various procedures to estimate impairments of radio wave signal on earth–space path (ITU-R P 618-9, 2007). The ITU-R model is the most widely accepted internationally for the prediction of rain effects on communication systems. The input parameters required for the ITU-R model are:

- frequency of operation f in GHz;
- the k and alpha parameter of (ITU-R P838, 2005), which depends on frequency.

Table 4

Measured one-minute rainfall rates for tropical and subtropical locations around the world compared with some tropical and subtropical stations in Nigeria for the present study.

Country	Station name	Climatic zone	Measured rainfall rates (mm/h)
India	Tirupati	Sub-tropical	80.0
	New Delhi	Semi-arid	120.0
	Shillong	Tropical	130.0
	Calcutta	Tropical	130.0
	Bombay	Tropical	130.0
Nigeria	Abakaliki	Tropical wet	125.0
	Owerri	Tropical wet	125.0
	Umahia	Tropical wet	125.0
Kenya	Nairobi	Sub-tropical	65.0
Brazil	Gov. Valadares	Sub-tropical	65.0
	Fortaleza	Sub-tropical	82.3
	Rio de Janerio	Sub-tropical	82.6
	Belem	Sub-tropical	124.3
	Manaus	Sub-tropical	109.3
	Pta. Das Lages	Sub-tropical	104.8
	Brasilia	Sub-tropical	82.7
	Sao Paulo	Sub-tropical	82.9
P. Alegre	Sub-tropical	90.0	
Nigeria	Jos	Sub-tropical	91.0
Nigeria	Markudi	Sub-tropical	94.0
Indonesia	Surabaya	Tropical	119.6
Cameroon	Douala	Tropical wet	126.0
Nigeria	Yenagoa	Tropical wet	124.0
Congo	Brazzaville	Tropical	104.7
Nigeria	Benin	Tropical wet	105.0
Nigeria	Calabar	Tropical wet	105.0
Vietman	Ho-Chimin	Tropical	111.0
Nigeria	Akwa	Tropical wet	111.0
Nigeria	Enugu	Tropical wet	111.0
Australia	Darwin	Tropical	76.6
Nigeria	Ikeja	Tropical wet	79.0
Malaysia	Ipoh	Tropical	250.0
Hong-Kong	Hong-Kong	Tropical	100.0
USA	Miami-Florida	Tropical	107.0

the elevation angle to the satellite in degree;
 the polarization tilt angle with respect to the horizontal (0° for horizontal polarization, 90° for vertical polarization and 45° for circular polarizations) in degree. Horizontal polarization was used in this study; and

the altitude of the ground station above sea level in km; (see Appendix A for the procedure)

$R_{0.01}$ point rainfall rate for the location of interest for 0.01% on an average year in mm/h. Table 3 shows the rainfall rate $R_{0.01}$, for each station for 0.01% on an average year (Omotosho, 2008). The altitudes of each station above sea level were derived from GTOPO30 (NASA USA) with a Matlab program, while the zero-degree isotherm height for each station were derived from AIRS satellite (5 years) data and rain height for each station were computed using ITU-RP 839 (2001) model, see Table 1. The elevation and azimuthal angle to the Nigeria Communication Satellite-1 (NigComSat-1) in degree was estimated with a Matlab program. Other Matlab programs named *EffPL*, and *RP618* were written to calculate the effective path length through rain and to implement the ITU-R P 618-9, (2007) procedure. These Matlab programs can be linked to Microsoft Excel and called as a function to generate and plot results for frequencies between 10 and 55 GHz.

3. Results

Table 5 shows some geometrical parameters relevant for links to NigComSat-1 downlink frequencies at Ku, Ka and extended to V bands (for future Nigerian communication satellite operating on a V-band) at the 37 stations. The elevation and azimuth angles to NigComSat-1 were calculated for each location (Rogers et al., 1997). The frequency-dependent effective path lengths through the rain-filled regions were also calculated for 0.01% unavailability. Figs. 3–5 show rain attenuation cumulative distribution for links to NigComSat-1 downlink frequencies, for horizontal polarization for a very small aperture terminal (VSAT) at Ku (11 GHz), Ka (20 GHz) and V-band (40 GHz) for 0.01–10% unavailability. At Ku-band downlink, Fig. 1 shows that 99.99% availability (about 53 min outage in a year = 8.7 s outage per day) is possible in all the 37 stations in Nigeria, since NigComSat-1 carries three Ku antenna spot beams of EIRP between 48 and 52 dBW and rain attenuation for all the six regions ranges from 8.8 dB in NE (Damaturu) to 15 dB in SS (Yenagoa). The antenna

Table 5
Some geometrical parameters relevant to NigComSat-1 at downlink frequencies at Ku, Ka and extended to V bands for future communication satellite at 0.01% unavailability.

Regions	State capitals	Station latitude	Station longitude	Station height h_s (km)	Rain height h_r (km)	One-minute rain rate $R_{0.01}$ (mm/h)	Dish elevation to satellite	Dish azimuth to satellite	Slant path length L_s (km)	Horizontal projection length L_c (km)	Effective path-length through rain		
											Ku_down $f = 11$ GHz L_r (km)	Ka_down $f = 20$ GHz L_r (km)	V_down $f = 40$ GHz L_r (km)
South West	Abeokuta	7.07	3.21	0.074	4.77	87.0	44.4	261.2	6.71	4.80	1.92	3.91	4.90
	Adoekiti	7.42	5.13	0.363	4.75	92.0	46.5	260.2	6.05	4.16	1.76	3.61	4.58
	Akure	7.18	5.12	0.303	4.75	94.0	46.5	260.5	6.13	4.22	1.75	3.60	4.59
	Ibadan	7.21	4.01	0.134	4.76	93.0	45.3	260.8	6.51	4.58	1.82	3.73	4.73
	Ikeja	6.35	3.20	0.038	4.76	79.0	44.5	262.1	6.74	4.81	2.05	4.12	5.08
	Osogbo	7.42	4.31	0.229	4.76	94.0	45.6	260.5	6.34	4.44	1.78	3.66	4.65
South East	Abakaliki	6.18	8.70	0.149	4.77	125.0	50.7	260.6	5.97	3.78	1.45	3.15	4.24
	Akwa	6.12	7.04	0.159	4.75	111.0	48.8	261.3	6.10	4.02	1.58	3.36	4.41
	Enugu	6.24	7.24	0.139	4.75	111.0	49.0	261.0	6.11	4.01	1.58	3.36	4.42
	Owerri	5.19	7.07	0.158	4.75	125.0	49.0	262.6	6.08	3.99	1.48	3.18	4.24
	Umuahia	5.30	7.33	0.165	4.75	125.0	49.3	262.3	6.05	3.94	1.48	3.18	4.24
South South	Asaba	6.10	6.44	0.152	4.74	112.0	48.2	261.5	6.15	4.10	1.57	3.33	4.39
	Benin	6.22	5.39	0.042	4.74	105.0	47.1	261.7	6.41	4.37	1.68	3.53	4.57
	Calabar Port	4.55	8.25	0.370	4.76	105.0	50.4	263.2	5.70	3.63	1.6	3.36	4.37
	harcourt	4.43	7.02	0.018	4.74	116.0	49.0	263.7	6.26	4.10	1.58	3.36	4.43
	Uyo	5.00	7.57	0.163	4.75	124.0	49.6	262.7	6.02	3.90	1.48	3.18	4.25
	Yenagoa	4.55	6.16	0.093	4.74	124.0	48.1	263.7	6.24	4.17	1.52	3.24	4.30
Middle Belt	Abuja	9.04	7.28	0.334	4.76	94.0	48.5	257.2	5.91	3.92	1.68	3.52	4.53
	Ilorin	8.32	4.34	0.304	4.78	89.0	45.4	259.3	6.29	4.41	1.82	3.72	4.69
	Lafia	8.29	8.34	0.403	4.77	89.0	49.8	257.7	5.72	3.69	1.72	3.57	4.57
	Lokoja	7.47	6.44	0.204	4.75	93.0	47.9	259.6	6.13	4.11	1.75	3.63	4.65
	Markurdi	7.41	8.35	0.142	4.76	94.0	50.0	259.0	6.03	3.87	1.71	3.60	4.66
	Minna	9.33	6.33	0.152	4.79	84.0	47.4	257.0	6.30	4.26	1.85	3.83	4.85
	Jos	9.58	8.57	1.110	4.76	91.0	49.7	255.8	4.79	3.10	1.55	3.18	4.04
North West	Birini	12.28	4.08	0.244	4.78	67.0	44.2	254.7	6.51	4.66	2.11	4.23	5.17
	Kebbi												
	Gusau	12.18	6.27	0.440	4.78	69.0	46.5	253.6	5.98	4.12	1.98	4.00	4.94
	Kaduna	10.32	7.25	0.605	4.77	86.0	48.1	255.5	5.60	3.74	1.71	3.53	4.48
	Kano	11.56	8.26	0.566	4.77	70.0	48.8	253.2	5.59	3.68	1.9	3.86	4.80
	Kastina	12.56	7.33	0.590	4.77	65.0	47.5	252.5	5.67	3.83	1.99	3.99	4.90
North East	Sokoto	13.05	5.15	0.247	4.79	60.0	45.0	253.2	6.42	4.54	2.21	4.40	5.33
	Bauchi	10.18	9.46	0.665	4.78	78.0	50.5	254.5	5.33	3.39	1.77	3.62	4.57
	Damaturu	11.44	11.58	0.451	4.77	66.0	52.4	251.3	5.45	3.33	1.94	3.96	4.94
	Dutse	11.43	9.25	0.452	4.78	70.0	49.9	252.8	5.66	3.64	1.91	3.91	4.88
	Gombe	10.19	11.02	0.422	4.79	71.0	52.2	253.5	5.53	3.39	1.89	3.88	4.88
	Jalingo	8.54	11.22	0.304	4.75	95.0	52.9	256.0	5.57	3.36	1.62	3.45	4.51
	Maiduguri	11.51	13.09	0.343	4.78	68.0	53.9	250.0	5.49	3.24	1.91	3.95	4.98
	Yola	9.07	12.24	0.207	4.77	82.0	53.9	254.5	5.65	3.33	1.77	3.73	4.80

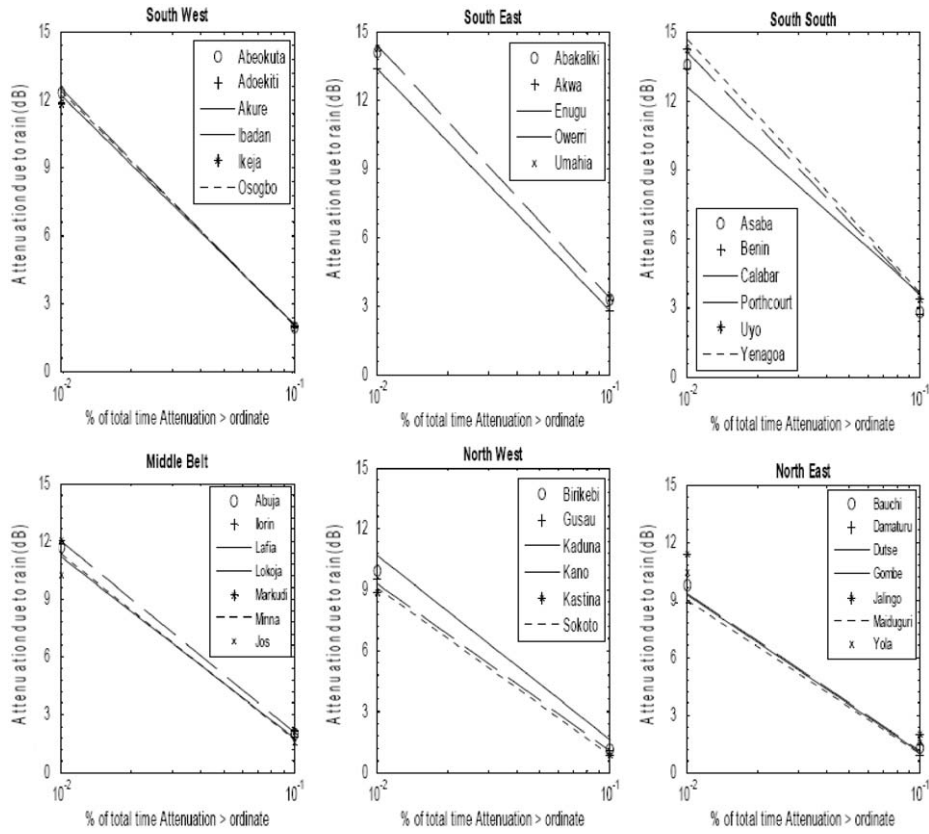

Fig. 3. Rain attenuation cumulative distribution for links to NigComSat-1 at Ku downlink frequency (11 GHz).

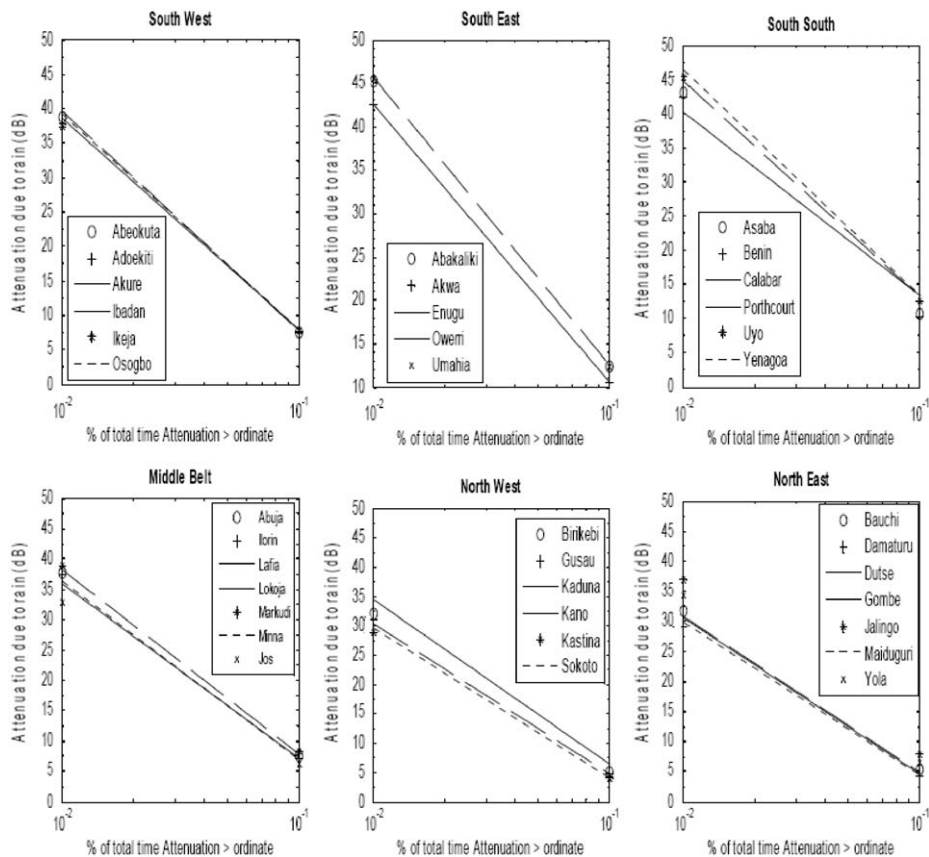

Fig. 4. Rain attenuation cumulative distribution for links to NigComSat-1 at Ka downlink frequency (20 GHz).

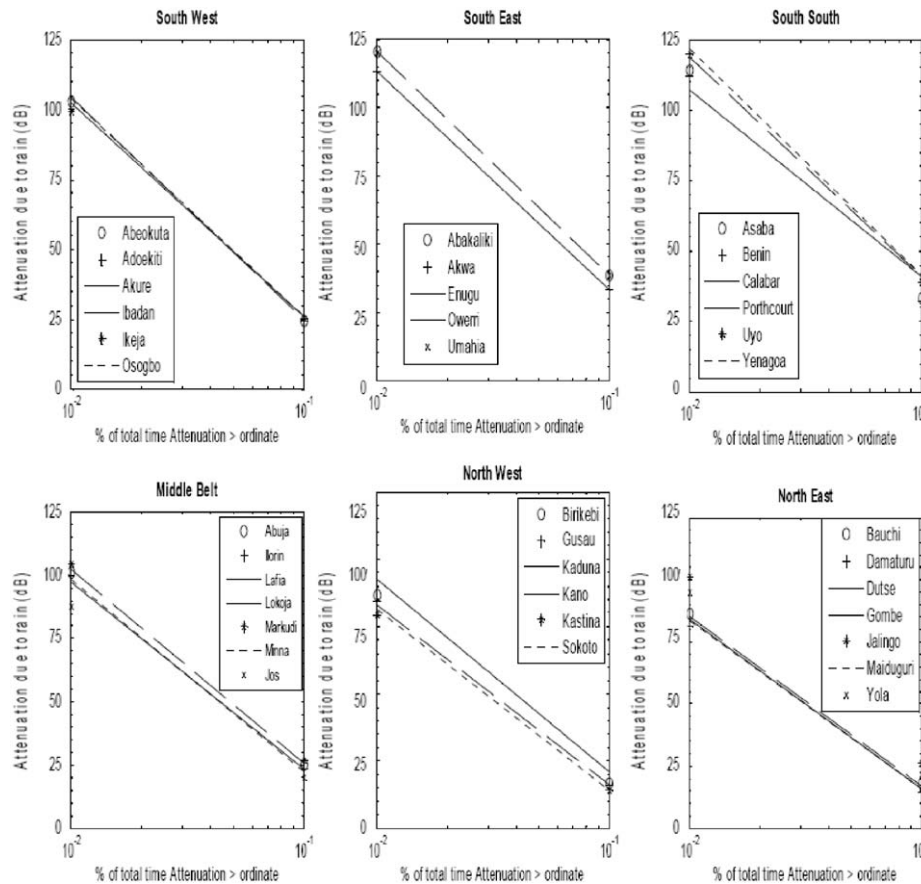

Fig. 5. Rain attenuation cumulative distribution for links to NigComSat-1 at V downlink frequency (40 GHz).

spot beam (of 48–52 dBW) power is enough to overcome attenuation due to rain at Ku-band. Measurements at Ku-band with INTELSAT VI at 11 GHz in Singapore, a tropical region like Nigeria (Timothy et al., 2000) shows several classes of rain fade levels from 2 to 15 dB.

For the Ka-band downlink, the cumulative distribution of rain attenuations in Fig. 2 shows that 99.99% availability is possible in all the 37-locations in Nigeria. Rain attenuations at Ka-band in all the 37 stations ranges from 28.9 to 46.4 dB, with NW regions (Kastina) being the lowest and SS regions (Yenagoa) the highest. The Ka-band antenna spot beam (EIRP) is between 52 and 55 dBW and allowances have to be made for other losses such as gas, scintillation, cloud, system loss, noise figure and free space loss, etc. The only practicable availability is 99.9% (0.1% unavailability and 8.76 h outage in a year) as the loss at this availability for all locations is between 3.99 dB (in Kastina) to 13.47 dB (in Yenagoa). Studies on Ka-band rain attenuation with ACTS satellite (VSAT beacon receivers) for a 10-year period in the USA show that at Ka-band (27.5 GHz) under moderate elevation angles, rain attenuation exceeds 20 dB for 99.9% of a typical year and that fading becomes worse for low-elevations and for higher rainfall climates in the US (Roberto, 1997).

For the V-band downlink, Fig. 3 shows that 99.99% availability is most improbable at all the 37 stations in Nigeria, as rain attenuation is between 79.2 and 121.7 dB. Availability level of 99.9% is only practicable in the NW (except Kaduna) and the NE (except Jalingo and Yola), with attenuation between 14 and 17.9 dB. There will be total fade out of signals during rain in the SS, SE, SW and MB regions at 99.9% availability as attenuation is between 20 and 41 dB. The only possible availability level for all

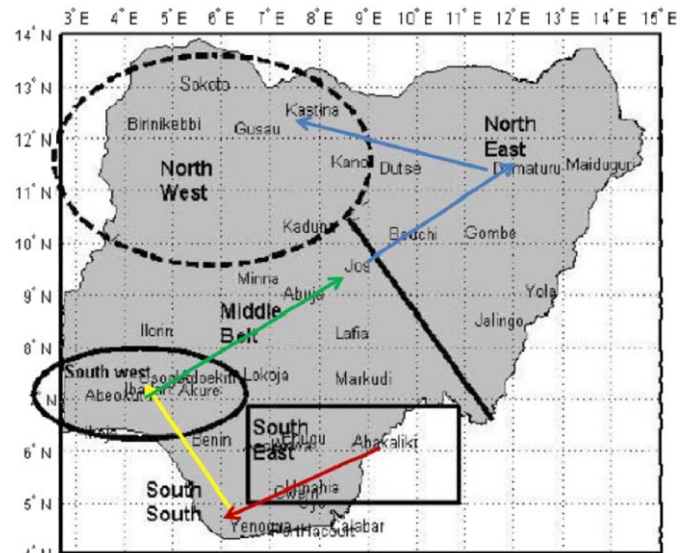

Fig. 6. Pattern of rain impairment of satellite signal in the six regions in Nigeria. Red = very high, yellow = high, green = medium, blue = low attenuation.

regions at V-band is 99.8% (17.52 h outage in a year = 2.88 min outage per day) as rain attenuation is between 6.3 dB (at Kastina and Sokoto) and 24.1 dB (in Calabar). The V-band is still at experimental stage and has not been commercialized. Measurement with ITALSAT (at a beacon frequency of 40 and 50 GHz) shows a minimum rain fade level (in 10 years of measurements) of

25 dB at 40 GHz (Van de Kamp and Castanet, 2002). Fig. 6 shows the patterns and summaries of the impairment by rain in all the six regions of Nigeria. The arrows point in the direction of decreasing effect of rain attenuation. A red arrow means very high, yellow high, green medium and blue low attenuation.

4. Conclusion

The effect of rainfall on fixed satellite service at Ku, Ka and V bands has been investigated for links to Nigeria Communication Satellite one (NigComSat-1) based on local input data, for time availability of 99–99.99% (87.6 h to 53 min outage of signal) in an average year for 37 stations in Nigeria. The results reveal the regional patterns of rain impairment in Nigeria. In general, impairments decrease from the south to the north.

Acknowledgements

The support of NASA Goddard Space Flight Centre Distributed Active Archive Centre (DAAC) for sending 60 CDs, 1 data tape of TRMM (50 GB of) data covering 1997–2006 and AIRS Satellite 2002–2006, for Ph. D. research in satellite to ground radio waves propagation modeling in Nigeria, is gratefully acknowledged.

Appendix A. : Calculation of long-term rain attenuation statistics from point rainfall rate

The following ITU-RP 618, 2007 procedure provides estimates of the long-term statistics of the slant-path rain attenuation at a given location for frequencies up to 55 GHz. The following parameters are required:

- $R_{0.01}$ point rainfall rate for the location for 0.01% of an average year (mm/h)
- h_s height above mean sea level of the earth station (km)
- θ elevation angle (degrees)
- φ latitude of the earth station (degrees)
- f frequency (GHz)
- R_e effective radius of the Earth (8500 km) (Fig. A1)

Step 1: determination of the rain height, h_R , as given in Recommendation ITU-R P.839.

Step 2: for $\theta \geq 5^\circ$, the slant-path length, L_S , below the rain height is computed from

$$L_S = \frac{(h_R - h_s)}{\sin \theta} \text{ km} \quad (\text{A.1})$$

For $< 5^\circ$, the following formula is used:

$$L_S = \frac{2(h_R - h_s)}{(\sin^2 \theta + 2(h_R - h_s)/R_e)^{1/2} + \sin \theta} \text{ km} \quad (\text{A.2})$$

If $h_R - h_s \leq 0$, then predicted rain attenuation for any time percentage is zero and the following steps are not required.

Step 3: the horizontal projection, L_G , of the slant-path length is calculated from

$$L_G = L_S \cos \theta \text{ km} \quad (\text{A.3})$$

Step 4: the rainfall rate, $R_{0.01}$, exceeded for 0.01% of an average year (with an integration time of 1 min) was obtained from TRMM data. If $R_{0.01}$ is equal to zero, the predicted rain attenuation is zero for any time percentage and the following steps are not required.

Step 5: obtain the specific attenuation, γ_R , using the frequency-dependent coefficients given in recommendation ITU-R P.838 and the rainfall rate, $R_{0.01}$, determined from Step 4, by using

$$\gamma_R = k(R_{0.01})^\alpha \text{ (dB/km)} \quad (\text{A.4})$$

Step 6: the horizontal reduction factor, $r_{0.01}$, for 0.01% of the time is given by

$$r_{0.01} = \frac{1}{1 + 0.78\sqrt{L_G\gamma_R/f} - 0.38(1 - e^{-2L_G})} \quad (\text{A.5})$$

Step 7: the vertical adjustment factor, $\nu_{0.01}$, for 0.01% of the time is given by

$$\xi = \tan^{-1} \left(\frac{h_R - h_s}{L_G r_{0.01}} \right)^\circ$$

For $\xi > \theta$,

$$L_R = \frac{L_G r_{0.01}}{\cos \theta} \text{ km}$$

Else,

$$L_R = \frac{(h_R - h_s)}{\sin \theta} \text{ km}$$

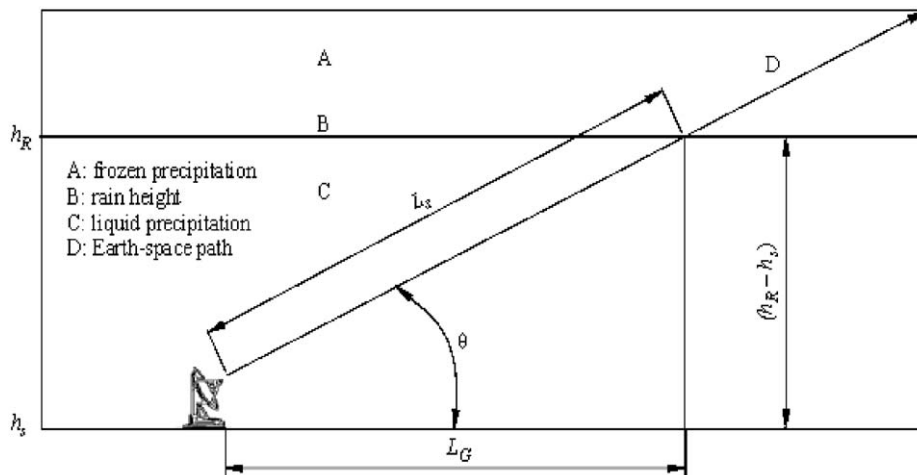

Fig. A1. Schematic presentation of an Earth-space path giving the parameters to be input into the attenuation prediction process.

If $|\varphi| < 36^\circ$,
 $\chi = 36 - |\varphi|^\circ$
 Else,
 $\chi = 0^\circ$

$$\nu_{0.01} = \frac{1}{1 + \sqrt{\sin \theta (31(1 - e^{-(\theta/(1+\chi))})[\sqrt{L_R \gamma_R} / f^2 - 0.45])}}$$

Step 8: the effective path length is

$$L_E = L_R \nu_{0.01} \text{ km} \quad (\text{A.6})$$

Step 9: the predicted attenuation exceeded for 0.01% of an average year is obtained from

$$A_{0.01} = \gamma_R L_E \text{ dB} \quad (\text{A.7})$$

Step 10: the estimated attenuation to be exceeded for other percentages of an average year, in the range 0.001–5%, is determined from the attenuation to be exceeded for 0.01% for an average year

$$\begin{aligned} \text{if } p \geq 1\% \text{ or } |\varphi| \geq 36^\circ : & \quad \beta = 0 \\ \text{if } p < 1\% \text{ and } |\varphi| < 36^\circ \text{ and } \theta \geq 25^\circ : & \quad \beta = -0.005(|\varphi| - 36) \\ \text{Otherwise :} & \quad \beta = -0.005(|\varphi| - 36) + 1.8 - 4.25 \sin \theta \end{aligned}$$

$$A_p = A_{0.01} \left(\frac{p}{0.01} \right)^{-(0.655 + 0.033 \ln(p) - 0.045 \ln(A_{0.01}) - \beta(1-p) \sin \theta)} \text{ dB} \quad (\text{A.8})$$

Reference

Adeyewa, Z. Debo, Nakamura, Kenji, 2003. Validation of TRMM radar data over major climatic regions in Africa. *J. Appl. Meteorol. Am. Metrol. Soc.*
 Ajayi, G.O., Ezekpo, S.U.B., 1988. Development of climatic maps of rainfall rate and attenuation for microwave applications in Nigeria. *Niger. Eng.* 23 (4), 13–30.
 Ajayi, G.O., Feng, S., Radicella, S.M., Reddy B.M., 1996. Hand Book on radio propagation related to satellite communications in tropical and sub-tropical countries UNESCO and ICTP, U. R. S. I Standing committee on developing countries.
 Brussaard, G., Dijk, J., Wijdemans, L., 1993. 11 GHz satellite Beacon Data in the Western Pasific Basin, final report INTELSAT 770-B, Eindoven University of Technology and Surabaya Institute of Technology.
 Chieko Ito, Yoshio Hosoya, 2002. The Thunderstorm ratio as a regional Climatic parameter: its effects on different-integration-time rain rate conversion, rain attenuation, site-diversity and rain depolarization. The proceedings of URSI 2002, GA02 paper P0181.
 Gibson, J.D. (Ed.), 2002. The Communication Handbook, second ed.. CRC Press, LCC, pp. 59-1–59-16.
 Harris, R.A. (Ed.), 2002. COST Action 255, Radio waves Propagation Modeling for SATCOM Services at Ku-band and Above. European Space Agency publication Division Noordwijk, Netherlands.
 Huffman, G.J., Alder, R.F., Rudolf, B., Schneider, U., Keehn, P.R., 1995. Global precipitation estimates based on a technique for combining satellite-based

estimates, rain gauge analysis, and NWP model information. *J. Clim.* 8, 1284–1295.
 Ippolito, L.J., 1986. Radio wave Propagation in Satellite Communication. Van Nostrans, Reinhold, New York.
 Ippolito, L.J., Bauer, R., 2000. Summary of ACTS propagation Experiment, Proceedings of Sixth Ka-band utilization conference, Cleveland Ohio.
 ITU-R P 618-9, 2007. Propagation data and prediction methods required for the design of Earth-space telecommunication system.
 ITU-R; Recommendation P.838, 2005. Specific attenuation model for rain used in prediction methods.
 ITU-R; Recommendation P.839, 2001. Rain height model for prediction methods.
 Margarita, B.F., 2005. DSD variation on rain rate estimate algorithms of X-band polarimetric and radar and rainfall characterization in tropical environments using 2DVD, rain gauges and TRMM Data, M. Sc. Thesis University of Puerto Rico.
 McCarthy, D.K., Allnutt, J.E., Salazar, W.E., Omeata, E.C., Owolabi, B.R., Oladiran, T., Ojeba, E.B., Ajayi, G.O., Raji, T.I., Zaks, C., 1994. Results of 11.6 GHz radiometric experiment in Nigeria: second year. *Electron. Lett.* 30 (17).
 McCarthy, D.K., Allnutt, J.E., Salazar, W.E., Sitati, R.w., Okoth, M., Mutungi, M.J., Odhiambo, C.D., Zaks, C., 1994b. Results of an 11.6 GHz radiometric experiment in Kenya. *Second Year Electron. Lett.* 30 (17), 1450–1452.
 Migliora, C.G.S., Pontes, M.S., Silva Mello, L.A.R. 1990. Rain rate and attenuation measurements in Brazil, Preprint of URSI Comm. F, Open symposium on regional factors in predicting radio wave attenuation due to rain, Rio de Janeiro, Brazil, pp. 8–13.
 Moupfouma, F., 1987. Etude des precipitations et de leurs effets sur les liaisons hertziennes en visibility et par satellite dans les regions tropicales, These de Doctorat d Etat es-sciences physiques, CMET u Universite Paris Nord.
 Moupfouma, F., Martin, M., Spanjaard, N., Hughes, K., 1990. Rainfall rate characteristics for microwave system in tropical and equatorial areas. *Int. J. Satell. Commun.* 8, 151–161.
 Nirala, M.L., Cracknell, A.P., 2002. The determination of the three distribution of rain from the tropical rainfall measuring mission (TRMM) precipitation radar. *Int. J. Remote Sensing* 23 (20), 4263–4304.
 Omotosho, T.V., 2008. Studies of Propagation Impairments for Fixed Satellite Communication Links at the Microwave Frequencies in Nigeria, Ph. D. Thesis, (Unpublished) Department of Physics, Covenant University, Ota, Nigeria.
 Rice, P.L., Holmberg, N.R., 1973. Cumulative time Statistics of Surface-point Rainfall rates. *IEEE Trans. Com-21*, 1131–1136.
 Roberto J.A., 1997. Rain Fade Compensation Alternatives for Ka-band Communication Satellite, Third Ka-band Utilization Conference Sorrento Italy.
 Rogers, D.V., Ippolito, L.J., Davarian, F., 1997. System requirement for Ka-band Earth-satellite propagation data. *Proc. IEEE* 1985, 810–820.
 Sarkar, 1998. Some studies on attenuation and atmospheric water vapour measurement in India. *Int. J. Remote Sensing* 19 (3), 473–480.
 Sarkar, S.K., Ahmed, I., Prasad, M.V.S.M., Dutta, H.M., Reddy, B.M. 1992. Rain rate distribution over the Indian subcontinent—reference data manual.
 Sarkar, S.K., 1995. Characterization of rain rate and water vapour for satellite communication, Hand Book on Radio propagation Related to satellite communications in Tropical and Subtropical countries UNESCO and ICTP, U. R. S. I, Standing committee on developing countries.
 Sims, A.L., Jones, D.M.A., 1973. Climatology of instantaneous precipitation rates—Report AFCRL-TR-73-0171, National Technical Service (Springfield, VA).
 Timothy, K.L., Ong, J.T., Choo, E.B.L., 2000. Descriptive fade slope statistics on INTELSAT Ku-band communication link. *Electron. Lett.* 36 (20), 1733–1734.
 Van de Kamp, Castanet, L., 2002. Fade Dynamics Review, In: Proceedings of the First International Workshop COST Action 280.
 Yusof, M.A., Mohd, M., Hassan, S.I., 1990. Recommended conversion factors for Malaysian based on one year measured rainfall data. In: Proceedings of URSI Comm. F, open sympt on regional factors in predicting radiowave attenuation due to rain, Rio de Janeiro, Brazil, pp. 47–52.